

# Operating Instructions Emergency Stop Pushbutton ES-XA

# EUCHNER

## Scope

These operating instructions are valid for all emergency stop pushbuttons ES-XA. These operating instructions, the document *Safety information* and any available data sheet form the complete user information for your device.

## Supplementary documents

The overall documentation for this device consists of the following documents:

Document title (document number)	Contents	
Safety information (2525460)	Basic safety information	
Operating instructions (2512320)	(this document)	
Declaration of conformity	Declaration of conformity	
Any additions to the operating instructions	Take any associated additions to the operating instructions or data sheets into account.	

## Important!

Always read all documents to gain a complete overview of safe installation, setup and use of the device. The documents can be downloaded from [www.euchner.com](http://www.euchner.com). For this purpose, enter the doc. no. or the order number for the device in the search box.

## Safety precautions

### ! WARNING

- ▶ Please read this instruction sheet and the catalog for emergency stop pushbuttons of series ES-XA carefully before installing, wiring, setting up, maintaining or inspecting the emergency stop pushbutton. Make sure that the end user keeps the instruction sheet.
- ▶ Switch off the power supply for the ES-XA before installing, wiring, maintaining or inspecting the ES-XA. There is a danger of electric shock or a fire hazard if the power supply is not switched off.
- ▶ Use wires of the correct size in accordance with the voltage and current requirements. Unsuitable wires and loose connections can result in overheating and a fire hazard during operation. Ensure proper protection against electric shock.

## Notes about anti-twist safeguard

It is recommended to use a type label (ES-HAAV-0) to prevent emergency stop pushbutton ES-XA from twisting when the switch is reset from the latched position with excessive force. Align the thread-less side of the operator button with the upward-pointing "TOP" marking, the small marking on the type label's lug and the cut-out in the mounting plate.

## When using the ES-XA type label (ES-HAAV-0)

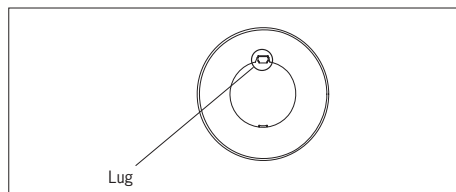

Break off the lug on the type label using pliers before installing the type label.

## Notes on operation

To ensure proper operation when using the emergency stop pushbutton for safety-related devices within a control system, observe the relevant safety standards and regulations in the respective country or region in accordance with the purpose of the machines and installations. A risk assessment should be performed for safety reasons before using the emergency stop pushbutton.

## Contact bouncing

The main normally closed contacts cause bouncing when the pushbutton is reset by pulling or turning. This contact bouncing should be taken into account when planning a control circuit (reference value: 20 ms).

## Handling

Never subject switches to excessive impacts or vibrations, because this can deform or damage the switch and therefore lead to malfunctions or to an operating failure.

## Rated data of the contacts (normally closed contacts)

Rated insulation voltage (U <sub>i</sub> )		250 V				
Conventional thermal current (I <sub>th</sub> )		5 A				
Rated operating voltage (U <sub>o</sub> )		30 V	125 V	250 V		
Rated operating current	Main contact	AC 50/60 Hz	Ohm resistive load (AC-12)	-	5 A	3 A
			Inductive load (AC-15)	-	3 A	1.5 A
		DC	Ohm resistive load (DC-12)	2 A	0.4 A	0.2 A
			Inductive load (DC-13)	1 A	0.22 A	0.1 A

## Technical data

Applicable standards	IEC 60947-5-1, EN 60947-5-1 IEC 60947-5-5, EN 60947-5-5 JIS C8201-5-1, UL508, CSA C22.2 No.14, GB14048.5
Standard operating conditions	Operating temperature -25 to +60 °C (no frost) Relative humidity: 45 to 85 % rel. h (no dew formation) Storage temperature: -45 to +80 °C (no frost)
Minimum direct opening force	40 N
Minimum direct opening	4.0 mm
Maximum travel	4.5 mm
Contact resistance	Max. 50 mΩ (initial value)
Insulation resistance	Min. 100 MΩ (500 V DC Megger)
Overvoltage category	II
Impulse withstand voltage	2.5 kV
Degree of contamination	3
Operating frequency	900 switching operations/hour
Mechanical life	Min. 250,000 switching operations
Electrical life	Min. 100,000 switching operations Min. 250,000 switching operations (24 V AC/DC, 100 mA)
Shock resistance	Extreme operating conditions: 150 m/s <sup>2</sup> Damage limits: 1,000 m/s <sup>2</sup>
Vibration resistance	Extreme operating conditions: 10 to 500 Hz; amplitude 0.35 mm, acceleration 50 m/s <sup>2</sup> Damage limits: 10 to 500 Hz, amplitude 0.35 mm, acceleration 50 m/s <sup>2</sup>
Degree of protection	IP65 (front)
Short-circuit protective device	Fuse 250 V/10 A (type aM IEC60269-1/IEC60269-2)
Conditional short-circuit current	1,000 A
Conductor cross-section to be used	Up to 1.25 mm <sup>2</sup> (up to AWG 16)
Recommended tightening torque for securing ring	0.88 Nm
<b>Characteristics acc. to EN ISO 13849-1</b>	
B <sub>100</sub> at DC-13 100 mA/24 V	1 x 10 <sup>6</sup>

## Dimension drawing

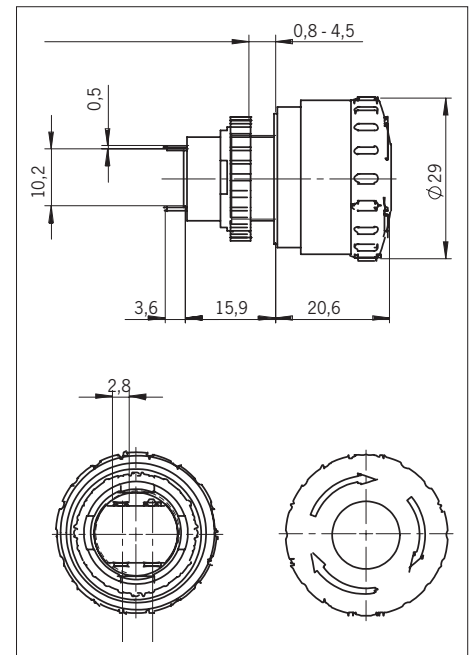

## Contact configurations (bottom view)

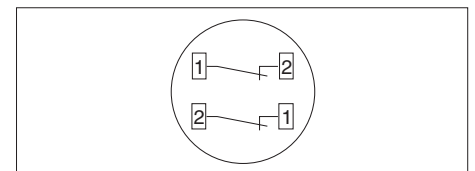

## Dimension of the mounting hole ES-XA

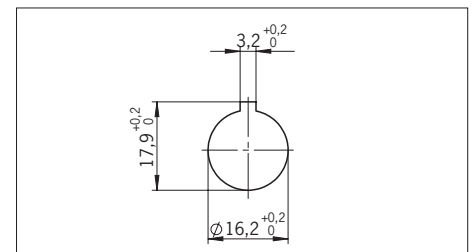

## Declaration of conformity

The EU declaration of conformity can be found at [www.euchner.com](http://www.euchner.com). Enter the order number of your device in the search box. The document is available under *Downloads*.

## Service

If servicing is required, please contact:

EUCHNER GmbH + Co. KG  
Kohlhammerstraße 16  
70771 Leinfelden-Echterdingen

## Service telephone:

+49 711 7597-500

## E-mail:

[support@euchner.de](mailto:support@euchner.de)

## Internet:

[www.euchner.com](http://www.euchner.com)

